

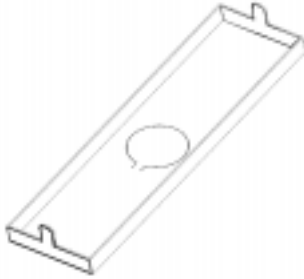
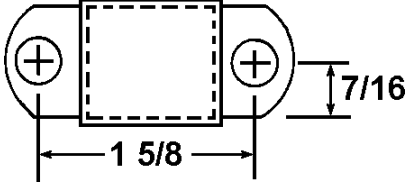
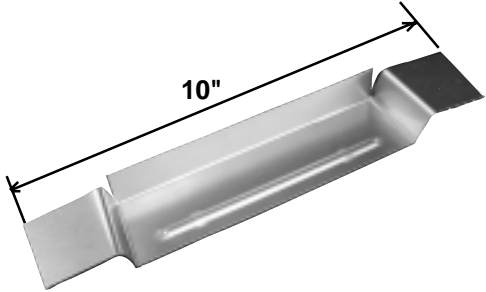
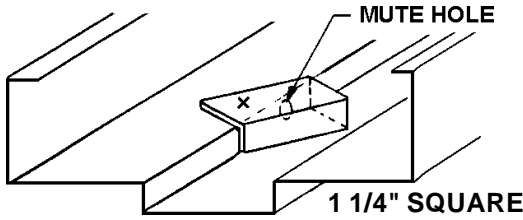

MISCELLANEOUS PARTS

Part Number	Description	
DC-TAB	<u>DUST COVER BOX</u> DUST BOX WITH TABS (24 GA EZ)	
DC-10 E	<u>DUST COVER</u> (25 GA EZ)	
DC-100 DC-100 E DC-100SS DC-75 DC-75 E	<u>DUST COVER BOX</u> 1" DEEP CRS 1" DEEP E.Z. 1" DEEP STAINLESSSTEEL 3/4" DEEP CRS 3/4" DEEP E.Z. (26 GA)	
DC-625 DC-626 DC-627	<u>SILENCER DUST COVER</u> 5/8" DEEP 3/4" DEEP 1" DEEP (26 GA)	
DC-50 DC-50 E DC-50 SS	<u>MUD BOX</u> CRS E.Z. STAINLESSSTEEL (26 GA)	
DC-4550	<u>WELD-IN DUST COVER</u> 4 1/2" HOLE PATTERN (24 GA)	

MISCELLANEOUS PARTS

Part Number	Description	
COMB-234 COMB-234E COMB-234P	<u>2 3/4" STRIKE BOX</u> CRS E.Z. with PROJECTIONS (16 GA)	
COMB-478 COMB-478E COMB-478-132 COMB-478P	<u>4 7/8" STRIKE BOX</u> with MORTAR GUARD CRS E.Z. with .032 OFFSET with PROJECTIONS (16 GA)	
MA-1216 MA-1216 E MA-1219	<u>12" MASONRY ANCHOR</u> 16 GA 16 GA E.Z. 19 GA	
MA-1016 MA-1016 E	<u>10" MASONRY ANCHOR</u> 16 GA 16 GA E.Z	
YOKE-16 YOKE-14 YOKE-16 E YOKE-14 E	<u>YOKE FOR MASONRY ANCHOR</u> 16 GA 14 GA 16 GA E.Z. 14 GA E.Z.	
REVF-35 E	<u>REV. DOOR HINGE FILLER</u> 3501 PATTERN (25GA EZ)	

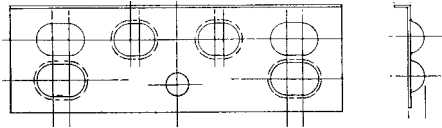
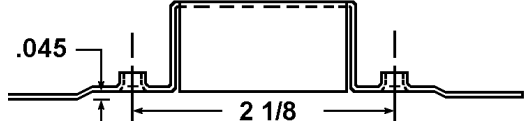
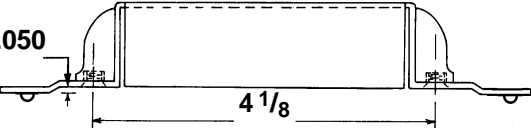
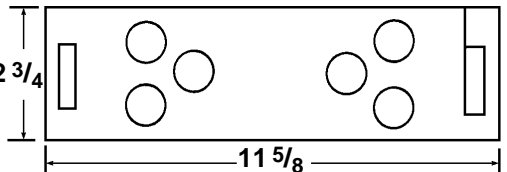
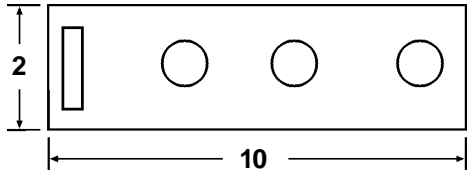
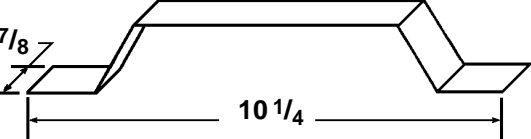
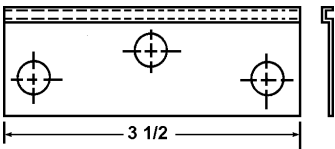

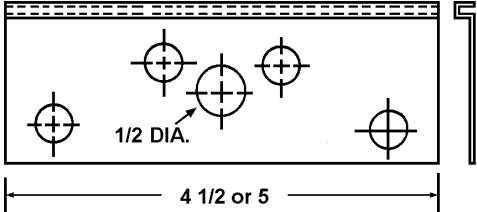
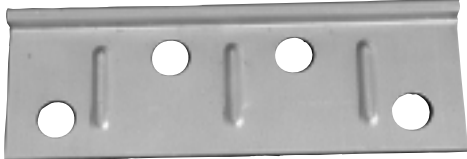
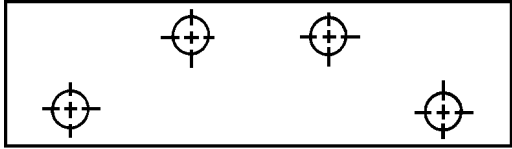
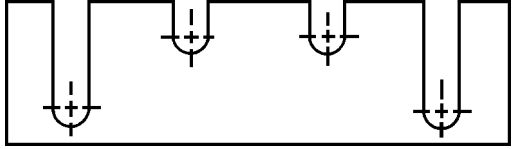
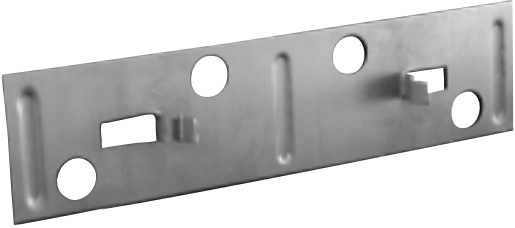
MISCELLANEOUS PARTS

Part Number	Description	
REVF-45 E REVF-45E 1/2 DIA REVF-50 E	<u>REV. DOOR HINGE FILLER</u> 4501 PATTERN 4501 PATTERN with HOLE 5001 PATTERN (25GA EZ)	
REVF-4520 E REVF-4520 E RIB	<u>REV. DOOR HINGE FILLER</u> 4501 PATTERN 4501 PATTERN with RIBS (20GA EZ)	
SHM-4522 E SHM-4516 E SHM-5022 E SHM-5016 E	<u>HINGE SHIM</u> 4501 PATTERN (22 GA EZ) 4501 PATTERN (16 GA EZ) 5001 PATTERN (22 GA EZ) 5001 PATTERN (16 GA EZ)	
SHM-4522-SL E SHM-4516-SL E SHM-5022-SL E SHM-5016-SL E	<u>HINGE SHIM, SLOTTED</u> 4501 PATTERN (22 GA EZ) 4501 PATTERN (16 GA EZ) 5001 PATTERN (22 GA EZ) 5001 PATTERN (16 GA EZ)	
SHM-SNAP IN	<u>SNAP-IN SHIM</u> 4501 PATTERN (25GA EZ)	

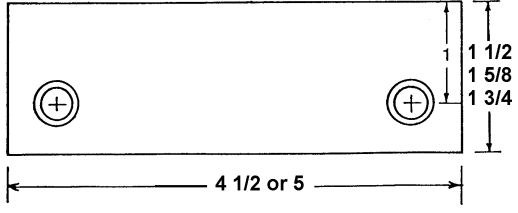
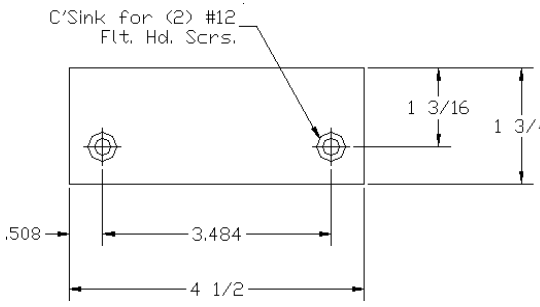
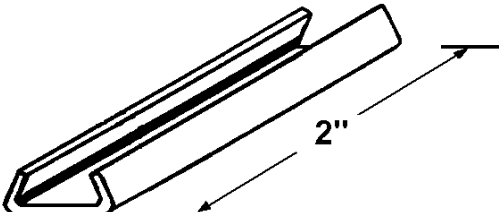
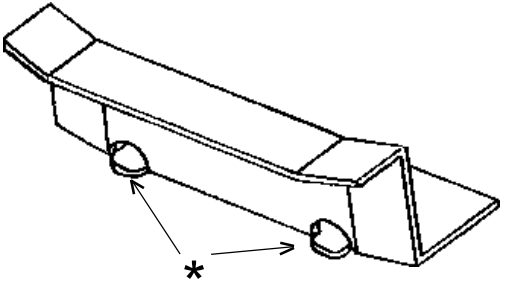
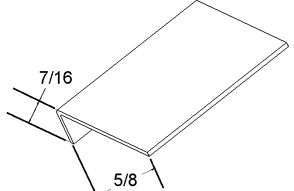
MISCELLANEOUS PARTS

Part Number	Description	
<p>HFILL-45112 HFILL-45158 HFILL-45134 HFILL-50112 HFILL-50134 HFILL-50158</p>	<p><u>HINGE FILLER BLANKS</u> 4 1/2" HINGE x 1 1/2" 4 1/2" HINGE x 1 5/8" 4 1/2" HINGE x 1 3/4" 5" HINGE x 1 1/2" 5" HINGE x 1 3/4" 5" HINGE x 1 5/8"</p> <p>(10GA)</p>	
<p>REVDRFILL-45134</p>	<p><u>HINGE FILLER FOR NON-HANDED DOORS</u></p> <p>(10GA)</p>	
<p>MC-200</p>	<p>SNAP MOLDING CLIP</p> <p>(18 GA)</p>	
<p>MUL-16 MUL-16 E MUL-16 NO TABS MUL-12 MUL-12 NO TABS</p>	<p><u>MULLION CLIP</u></p> <p>CRS E.Z. without TABS (*)</p> <p>(16 GA)</p> <p>CRS without TABS (*)</p> <p>(12 GA)</p>	
<p>CTWI-1 CTWI-3</p>	<p><u>WELD-IN CORNER TAB</u></p> <p>1 7/8" LONG 3 7/8" LONG</p> <p>(16 GA)</p>	

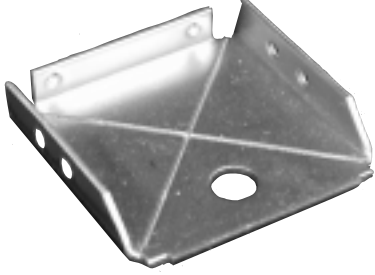
MISCELLANEOUS PARTS

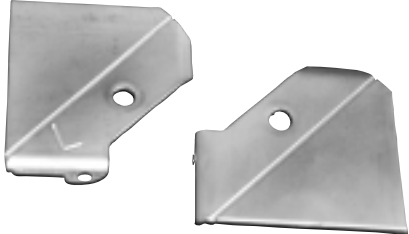
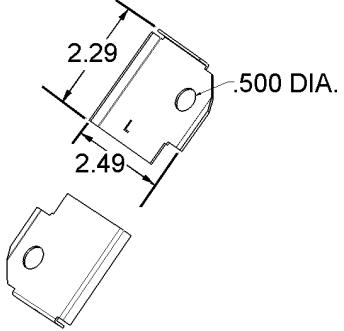
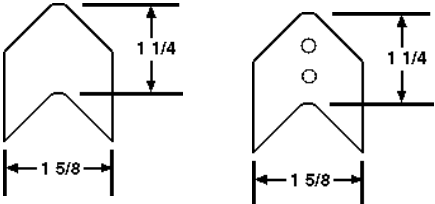
Part Number	Description	
CG-18 SCORED 4D	CORNER GUSSET (18 GA)	
CG-19F	CORNER GUSSET (19 GA)	
CG-2000-L CG-2000-R CG-2000-L NP CG-2000-R NP	CORNER GUSSET-LEFT CORNER GUSSET-RIGHT NO PROJECTIONS NO PROJECTIONS (18 GA)	
CG-2004-L CG-2004-R	DRYWALL CORNER GUSSET (18 GA)	
CG-18W CG-18WP	CORNER GUSSET WINDOW MOLDING GUSSET with PROJECTIONS (18 GA)	

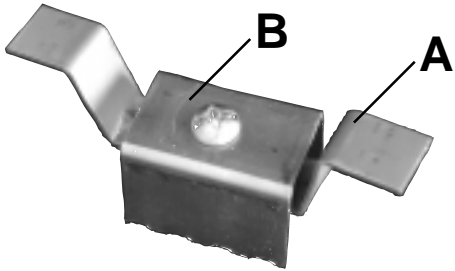
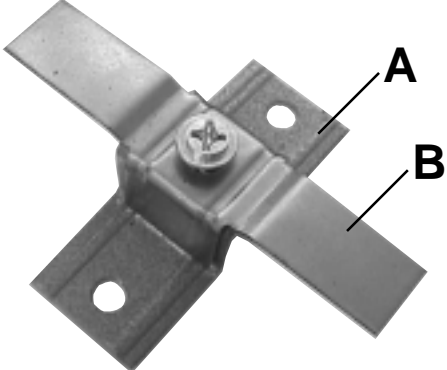
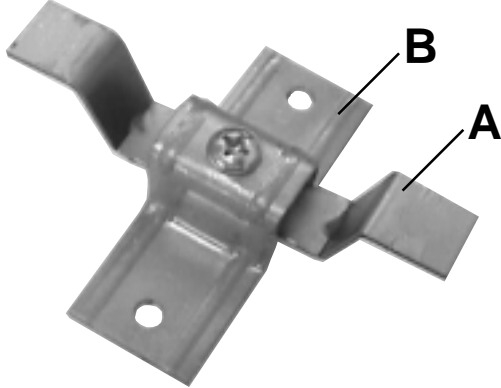
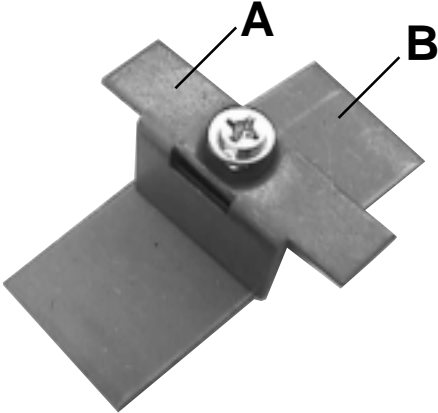

MISCELLANEOUS PARTS

Part Number	Description	
<p>PCLP-1 PCLP-1 E PCLP-1 W/PROJ.</p>	<p><u>PRESSURE CLAMP ASSY</u> (WOOD STUD)</p> <p>with PROJECTIONS ("A" 16 GA, "B" 18 GA.)</p>	
<p>PCLP-2 PCLP-2 W/PROJ</p>	<p><u>PRESSURE CLAMP ASSY</u> (WASHER HEAD SCREW SELF LOCATES & FILLS IN FRAME HOLE)</p> <p>with PROJECTIONS</p> <p>("A" 16 GA E.Z., "B" 18 GA.)</p>	
<p>PCLP-3 PCLP-3 E PCLP-3 W/PROJ PCLP-3 W/PROJ E</p>	<p><u>PRESSURE CLAMP ASSY</u> (STEEL STUD)</p> <p>"A" CRS, "B" EZ "A" EZ, "B" EZ "A" CRS with PROJ, "B" EZ "A" EZ with PROJ, "B" EZ</p> <p>(16 GA)</p>	
<p>PCLP - NS PCLP-NS W/PROJ</p>	<p><u>PRESSURE CLAMP ASSY</u> FITS NARROW STOP FRAMES (WASHER HEAD SCREW SELF LOCATES & FILLS IN FRAME HOLE)</p> <p>with WELD PROJECTIONS</p> <p>(14 GA)</p>	

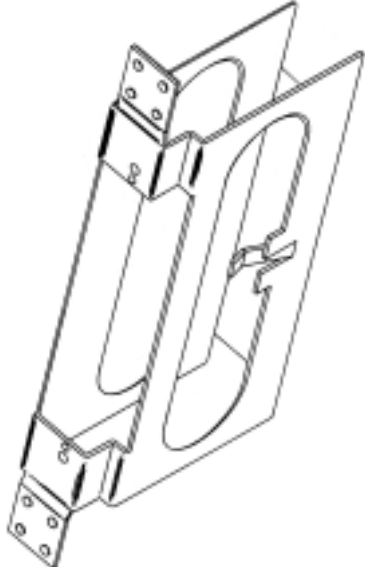
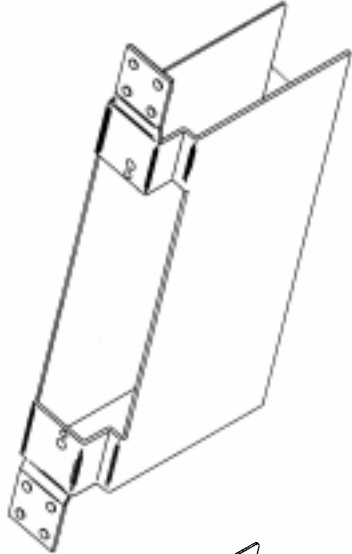
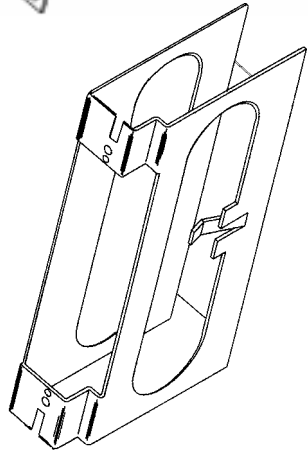
MISCELLANEOUS PARTS

Part Number	Description	
<p>MLB-BV-N 1164</p> <p>MLB-BV-P 1164</p> <p>MLB-SQ-N 1164</p> <p>MLB-SQ-P 1164</p> <p>MLB-SQ-P 1164CRS</p>	<p><u>MORTISE LOCK BOX</u></p> <p>BEVEL FACE WITH TABS, without WELD PROJECTIONS</p> <p>BEVEL FACE WITH TABS, with FOUR WELD PROJECTIONS</p> <p>SQUARE FACE WITH TABS, without WELD PROJECTIONS</p> <p>SQUARE FACE WITH TABS, with FOUR PROJECTIONS (14GA EZ)</p> <p>SQUARE FACE WITH TABS, with FOUR PROJECTIONS (14GA CRS)</p>	
<p>MLB-BVP1164 NOBL</p> <p>MLB-SQN1164 NOBL</p> <p>MLB-SQP1164 NOBL</p>	<p>BEVEL FACE WITH TABS, with FOUR WELD PROJECTIONS, FULL FACE</p> <p>SQUARE FACE WITH TABS, without WELD PROJECTIONS, FULL FACE</p> <p>SQUARE FACE WITH TABS, with FOUR WELD PROJECTIONS ON TABS, FULL FACE (14GA EZ)</p>	
<p>MLB-BV NO TABS</p> <p>MLB-SQ NO TABS</p> <p>MLB-SQ NOTABS CR</p>	<p>BEVEL FACE without TABS</p> <p>SQUARE FACE without TABS (14GA EZ)</p> <p>SQUARE FACE without TABS (14GA EZ)</p>	

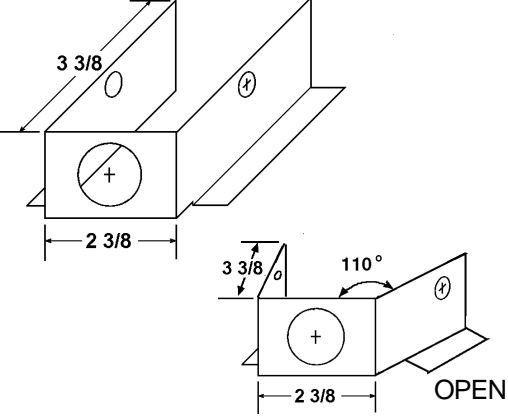
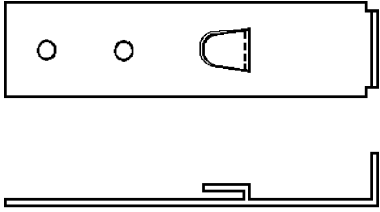
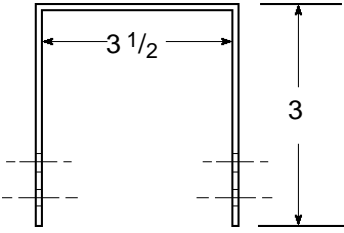

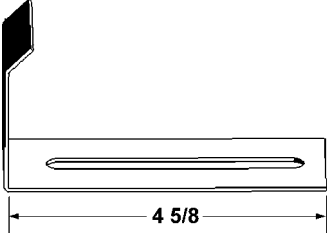
MISCELLANEOUS PARTS

Part Number	Description	
LRC-118 LRC-118 OPEN LRC-100 LRC-18B	<u>LOCK REINFORCING CHANNEL</u> 1 1/8" DIA. 1 1/8" DIA. 1" DIA. Blank (18 GA)	
DSA-18 DSA-15	<u>DRYWALL SILL ANCHOR (SNAP IN)</u> 2" TRIM, length= 4" 1 1/2" TRIM, length= 3 1/2" (18 GA)	
DSA-35 DSA-35 E	<u>DRYWALL SILL ANCHOR (WELD IN)</u> CRS ELECTRO ZINC (18 GA)	
EMA-58 E EMA-78 E	<u>EXISTING MASONRY ANCHOR</u> FOR 5/8" STOP FOR 7/8" STOP (17 GA EZ)	
AMBA 434-834	<u>ADJUSTABLE MULLION BASE ANCHOR</u> (16GA)	

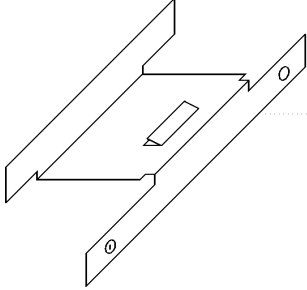
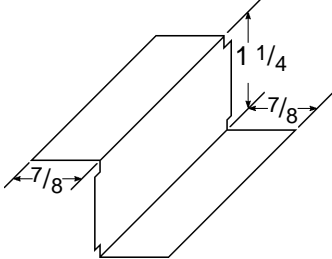
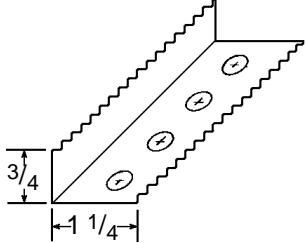
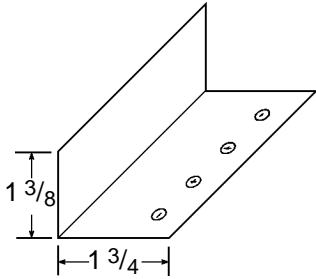
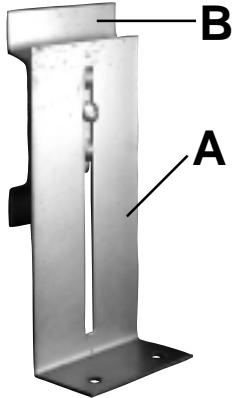
MISCELLANEOUS PARTS

Part Number	Description	
WSA-3 WSA-4	<u>WOOD STUD ANCHOR</u> 3" STUD 4" STUD (19 GA)	
Z-158 Z-250 Z-358	<u>"Z" CLIP</u> 1 5/8" LONG 2 1/2" LONG 3 5/8" LONG (16 GA)	
WSS-325	<u>WIRE STEEL STUD ANCHOR</u> 3 1/4" LONG (16 GA)	
FLA-275 FLA-325 FLA-400 FLA-500 FLA-600 FLA-700	<u>FLOOR ANCHOR</u> 2 3/4" LONG 3 1/4" LONG 4" LONG 5" LONG 6" LONG 7" LONG (16 GA)	
ADJFL-14 ADJFL-14 E ADJFL-14GA P ADJFL-16 ADJFL-16 E	<u>ADJUSTABLE FLOOR ANCHOR</u> 14 GA E.Z. with PROJECTIONS 16 GA E.Z.	

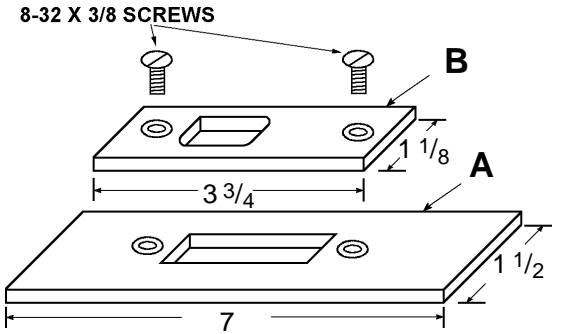
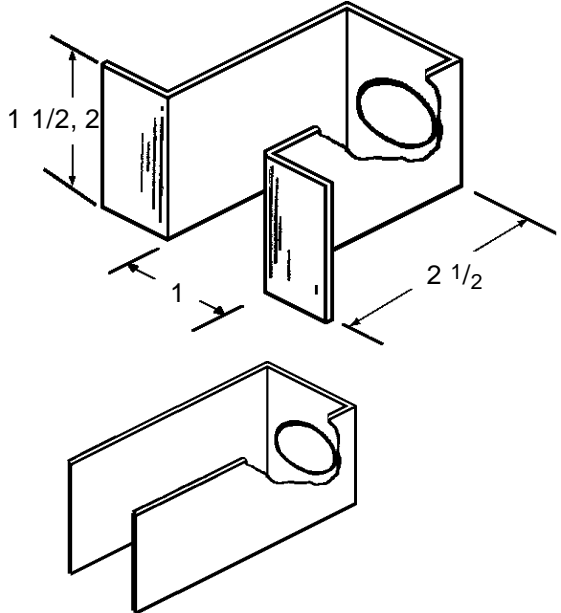
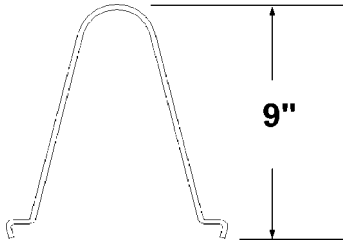
MISCELLANEOUS PARTS

Part Number	Description	
<p>FB-REV</p> <p>FB-REV ZYCH FB-REV A NO HOLE FB-REV B NO HOLE</p>	<p><u>REVERSIBLE FLUSH BOLT STRIKE & REINFORCEMENT</u></p> <p>YELLOW CHROMATE FINISH NO CENTER HOLE NO CENTER HOLE ("A" 14 GA, "B" 16 GA)</p>	
<p>EXB-100-18</p> <p>EXB-100-112-18</p> <p>EXB-58-16</p> <p>EXB-58-112-16</p> <p>EXB-58-112-18</p> <p>EXB-716-16 E</p> <p>EXB-UA-100-18</p>	<p><u>EXPANSION BOLT ANCHOR</u></p> <p>1" DIAMETER HOLE 2" WIDE (18 GA)</p> <p>1" DIAMETER HOLE, 1 1/2" WIDE (18 GA)</p> <p>5/8" DIAMETER HOLE 2" WIDE (16 GA)</p> <p>5/8" DIAMETER HOLE, 1 1/2" WIDE (16 GA)</p> <p>5/8" DIAMETER HOLE, 1 1/2" WIDE (18 GA)</p> <p>7/16" DIAMETER HOLE, 1 1/2" WIDE (16 GA)</p> <p>1" HOLE, 2" WIDE, CUSTOMER BENDS LEGS</p>	
<p>WMA-7</p>	<p>WIRE MASONRY ANCHOR</p> <p>(7GA PRE-GALV)</p>	
<p>ADJ FRAME GUIDE</p>	<p>ADJUSTABLE FRAME GUIDE</p> <p>(16 GA EZ)</p>	

MISCELLANEOUS PARTS

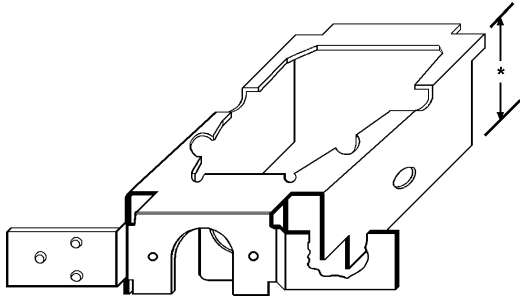
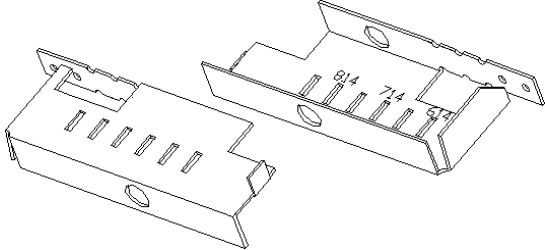
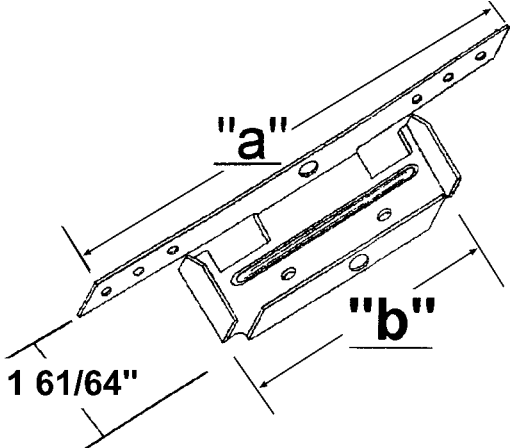
Part Number	Description																									
<p>CLB-BV-N 158 CLB-BV-N 158E CLB-BV-P 158 CLB-SQ-N 158 CLB-SQ-N 158E CLB-SQ-P 158 CLB-SQ-P 158E CLB-BV-N 11932 CLB-BV-P 11932 CLB-BV-N 11932E CLB-BV-P 11932E CLB-SQ-N 11932E CLB-SQ-P 11932E CLB-BV-N 158E062</p>	<p>CYLINDER LOCK BOX (CONFORMS TO ADA TEMPLATES) BEVEL, NO PROJECTIONS BEVEL, NO PROJ., E.Z. BEVEL, with PROJECTIONS SQUARE, NO PROJECTIONS SQUARE, NO PROJ, E.Z. SQUARE, with PROJECTIONS SQUARE, with PROJ, E.Z. BEVEL, NO PROJECTIONS BEVEL, with PROJECTIONS BEVEL, NO PROJ, E.Z. BEVEL, with PROJ, E.Z. SQUARE, NO PROJ, E.Z. SQUARE, with PROJ, E.Z. BEVEL, NO PROJ, E.Z., .062 OFFSET</p> <p>(16GA)</p>	 <p>*158 = 1 5/8" LEG HEIGHT *11932 = 1 19/32" LEG HEIGHT STANDARD OFFSET=.109, (UNLESS OTHERWISE NOTED)</p>																								
<p>SIA-ADJ 534-834</p>	<p>ADJUSTABLE SNAP-IN ANCHOR 5 3/4"- 8 3/4"</p> <p>2 PCS/ANCHOR (18 GA E.Z.)</p>																									
<p>SIA-534 ANCHOR SIA-LONG-434 SIA-LONG-534 SIA-LONG-614 SIA-LONG-634 SIA-LONG-714 SIA-LONG-734 SIA-LONG-814 SIA-LONG-834 SIA-LONG-1100 SIA-LONG-1134</p>	<p>SNAP IN ANCHOR FOR 4 3/4" - 11" FRAMES</p> <table border="1"> <thead> <tr> <th>"a"</th> <th>"b"</th> </tr> </thead> <tbody> <tr> <td>7"</td> <td>5-3/4"</td> </tr> <tr> <td>8-1/4"</td> <td>4-3/4"</td> </tr> <tr> <td>9-1/4"</td> <td>5-3/4"</td> </tr> <tr> <td>9-3/4"</td> <td>6-1/4"</td> </tr> <tr> <td>10-1/4"</td> <td>6-3/4"</td> </tr> <tr> <td>10-3/4"</td> <td>7-1/4"</td> </tr> <tr> <td>11-1/4"</td> <td>7-3/4"</td> </tr> <tr> <td>11-3/4"</td> <td>8-1/4"</td> </tr> <tr> <td>12-1/4"</td> <td>8-3/4"</td> </tr> <tr> <td>14-1/2"</td> <td>11"</td> </tr> <tr> <td>15-1/4"</td> <td>11 3/4"</td> </tr> </tbody> </table>	"a"	"b"	7"	5-3/4"	8-1/4"	4-3/4"	9-1/4"	5-3/4"	9-3/4"	6-1/4"	10-1/4"	6-3/4"	10-3/4"	7-1/4"	11-1/4"	7-3/4"	11-3/4"	8-1/4"	12-1/4"	8-3/4"	14-1/2"	11"	15-1/4"	11 3/4"	 <p>(18 GA E.Z.)</p>
"a"	"b"																									
7"	5-3/4"																									
8-1/4"	4-3/4"																									
9-1/4"	5-3/4"																									
9-3/4"	6-1/4"																									
10-1/4"	6-3/4"																									
10-3/4"	7-1/4"																									
11-1/4"	7-3/4"																									
11-3/4"	8-1/4"																									
12-1/4"	8-3/4"																									
14-1/2"	11"																									
15-1/4"	11 3/4"																									

MISCELLANEOUS PARTS

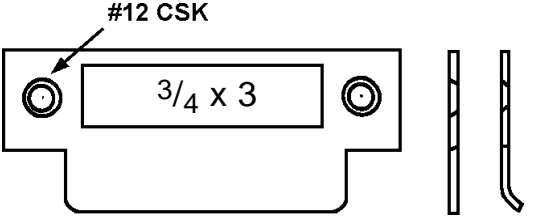
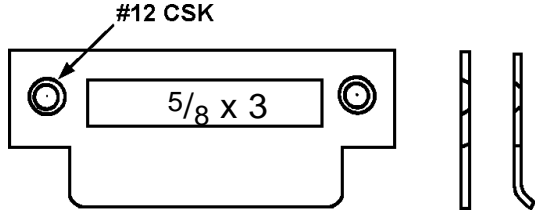
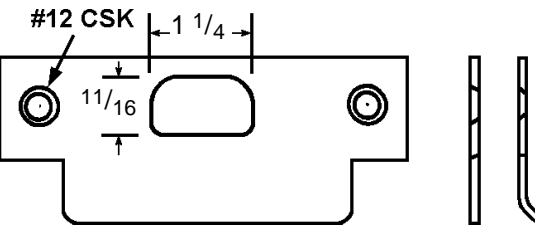
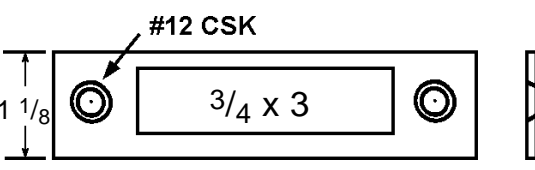
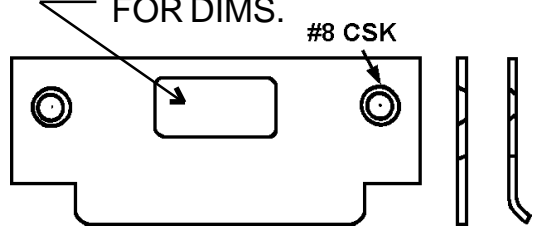
Part Number	Description	
<p>SP-47830C SP-47830S SP-478-BC SP-478-BS</p>	<p><u>4 7/8" STRIKE PLATE</u> CURVED STRAIGHT BLANK CURVED BLANK STRAIGHT (13 GA)</p>	 <p>#12 CSK 3/4 x 3</p>
<p>SP-47836C SP-47836S</p>	<p><u>4 7/8" STRIKE PLATE</u> CURVED STRAIGHT (13 GA)</p>	 <p>#12 CSK 5/8 x 3</p>
<p>SP-47812C SP-47812S</p>	<p><u>4 7/8" STRIKE PLATE</u> CURVED, ALSO IN BRASS OR CHROME STRAIGHT (13 GA)</p>	 <p>#12 CSK 1 1/4 11/16</p>
<p>SP-47831</p>	<p><u>4 7/8" STRIKE PLATE</u> (13 GA)</p>	 <p>#12 CSK 1 1/8 3/4 x 3</p>
<p>SP-41730S</p>	<p><u>4 7/8" STRIKE PLATE</u> STRAIGHT (17 GA)</p>	<p>SEE SP-478 FOR DIMS. #8 CSK</p> 

MISCELLANEOUS PARTS

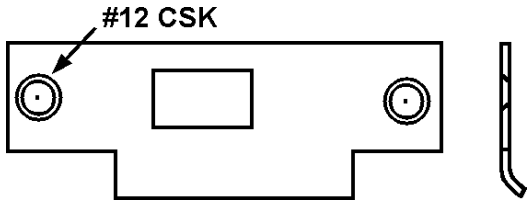
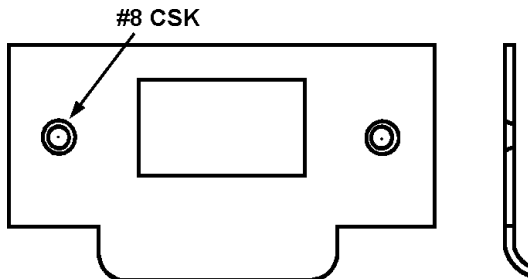
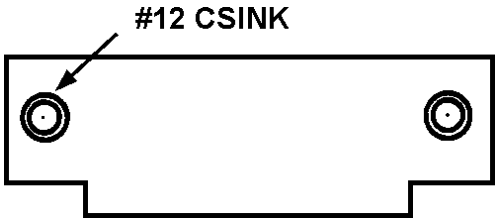
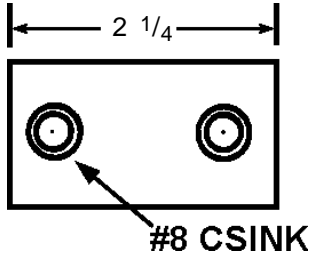
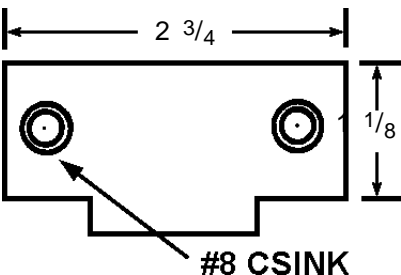
Part Number	Description	
SP-478RH SP-478LH	<u>4 7/8" STRIKE PLATE</u> RIGHT HAND LEFT HAND (13 GA)	
SP-23402	<u>2 3/4" STRIKE PLATE</u> (16 GA)	
FILP-47800	<u>4 7/8" FILLER PLATE</u> (13 GA)	
FILP-21401 FILP-21402 FILP-21403	<u>2 1/4" FILLER PLATE</u> 1 1/8" WIDE (11 GA) 1" WIDE (11 GA) 15/16" WIDE (16 GA)	
FILP-23401 FILP-23402	<u>2 3/4" FILLER PLATE</u> 1 3/8" WIDE 1 9/16" WIDE (16 GA)	

MISCELLANEOUS PARTS

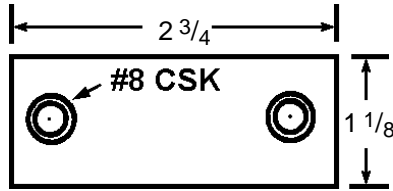
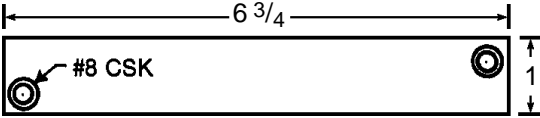
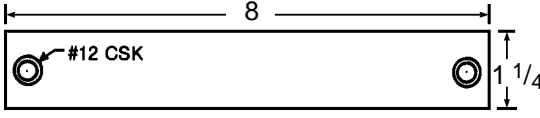
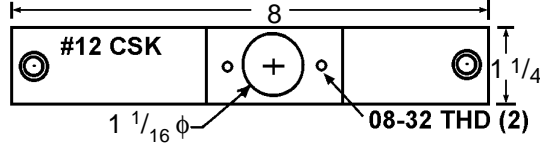
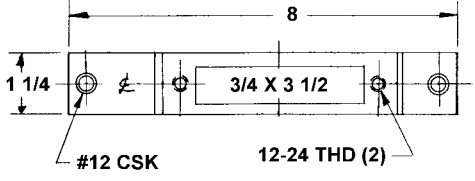
Part Number	Description	
FILP-23403 FILP-23404	<u>2 3/4" FILLER PLATE</u> (12 GA) (16 GA)	
FILP-63400	<u>6 3/4" FILLER PLATE</u> (11 GA)	
FILP-80010	<u>8" FILLER PLATE</u> (7 GA)	
CONV-86161	<u>CONVERSION PLATE</u> <u>#86 TO #161</u> (7 GA)	
CONV-86-ASA	<u>CONVERSION PLATE</u> <u>#86 TO ASA</u> (7 GA)	
LKRF-16100	<u>#161 LOCK REINFORCEMENT</u> (7 GA)	